



## Senator S80H Technical Datasheet

80 GHz Radar (FMCW) Level Transmitter for liquids with hygienic requirements

- Extensive choice of hygienic process connections
- Flush-mounted PEEK Lens antenna; CIP/SIP-suitable
- Small dead zone and beam angle for small and narrow tanks



<b>1</b>	<b>Product features</b>	<b>3</b>
<hr/>		
1.1	The FMCW radar level transmitter for liquids with hygienic requirements .....	3
1.2	Applications .....	4
1.3	Product family .....	5
1.4	Measuring principle.....	8
<b>2</b>	<b>Technical data</b>	<b>10</b>
<hr/>		
2.1	Technical data.....	10
2.2	Measuring accuracy .....	16
2.3	Minimum power supply voltage .....	18
2.4	Dimensions and weights .....	20
<b>3</b>	<b>Installation</b>	<b>24</b>
<hr/>		
3.1	Intended use .....	24
3.2	Pre-installation requirements .....	24
3.3	Installation .....	25
3.3.1	Pressure and temperature ranges.....	25
3.3.2	Recommended mounting position.....	26
3.3.3	Mounting restrictions.....	27
3.3.4	Process connections.....	29
<b>4</b>	<b>Electrical connections</b>	<b>33</b>
<hr/>		
4.1	Electrical installation: output options with cable gland .....	33
4.2	Electrical installation: output options with an M12 male connector.....	33
4.3	Non-Ex devices .....	34
4.4	Devices for hazardous locations .....	34
4.5	Networks .....	35
4.5.1	General information.....	35
4.5.2	Point-to-point connection.....	35
4.5.3	Multi-drop networks .....	36
<b>5</b>	<b>Order information</b>	<b>37</b>
<hr/>		
5.1	Order code .....	37

## 1.1 The FMCW radar level transmitter for liquids with hygienic requirements

This device is a non-contact radar level transmitter that uses FMCW technology. It measures distance, level and volume of liquids and pastes. It is ideal for measuring the level of hygienic liquids with its PEEK Lens antenna and wide range of process connection options.



- ① PEEK Lens antenna for the measurement of hygienic products
- ② 2-wire 80 GHz FMCW radar level transmitter
- ③ Large, backlit LCD screen with 4-button keypad can be used with a bar magnet without opening the housing cover. The software has a quick setup assistant for easy commissioning. 12 languages are available.
- ④ Aluminium or stainless steel housing

### Highlights

- 2-wire loop-powered 80 GHz transmitter – HART® 7
- Accuracy:  $\pm 2$  mm /  $\pm 0.08$ "
- PEEK Lens antenna measures distances up to 50 m / 164 ft at  $+150^{\circ}\text{C}$  /  $+302^{\circ}\text{F}$  and 25 barg / 362 psig
- Extensive choice of hygienic process connections: Tri-Clamp, Tuchenhagen VARIVENT®, SMS, DIN 11851, DIN 11864, NEUMO BioControl®
- Small dead zone and beam angle ( $8^{\circ}$  with DN40 / 1½" Lens antenna,  $10^{\circ}$  with DN25 / 1")
- Extensive choice of hygienic process connections (ideal for cleaning-in-place / sterilization-in-place (CIP-SIP) processes)
- One user interface for all applications
- Empty tank spectrum function eliminates false reflections caused by tank internals
- Diagnosis functions according to NAMUR NE 107
- Conforms to NAMUR Recommendations NE 21, NE 43 and NE 53
- Can measure in fast moving processes ( $\leq 60$  m/min / 196.85 ft/min)

### Industries

- Pharmaceutical
- Food & beverage

### Applications

- High and narrow tanks, small tanks and agitated tanks for the storage or process liquid applications
- Replacement of hygienic radar devices with lower frequencies
- High-accuracy applications where  $\pm 2 \text{ mm} / \pm 0.08''$  is required

## 1.2 Applications

### 1. Level measurement of liquids

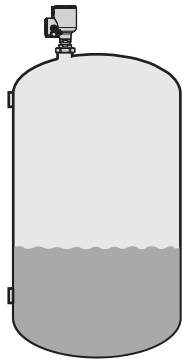

The level transmitter can measure the level of a wide range of liquid products on a large variety of installations within the stated pressure and temperature range. It is ideal for hygienic, pharmaceutical, and food and beverage applications. It does not require any calibration: it is only necessary to do a short configuration procedure.

### 2. Volume (mass) measurement

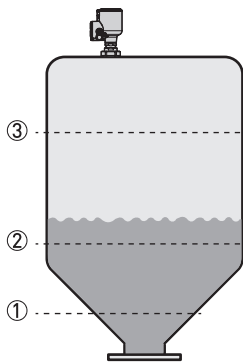

A strapping table function is available in the configuration menu for volume or mass measurement. Up to 50 volume (mass) values can be related to level values. For example:  
 Level ① = 2 m / Volume ① = e.g. 0.7 m<sup>3</sup>  
 Level ② = 10 m / Volume ② = e.g. 5 m<sup>3</sup>  
 Level ③ = 20 m / Volume ③ = e.g. 17 m<sup>3</sup>

This data permits the device to calculate (by linear interpolation) volume or mass between strapping table entries.

PACTware™ software and a DTM (Device Type Manager) is supplied free of charge with the device. This software permits the user to easily configure the device with a computer. It has a conversion table function with a large number of tank shapes.

### 1.3 Product family

#### Senator S24L Radar (24 GHz) for liquids in basic process applications



Designed for basic liquid applications, this market entry 24 GHz 2-wire FMCW radar transmitter provides accurate readings even in fast moving processes, in closed tanks or in the open air like rivers or dams. Its proven PP Drop antenna is insensitive to condensation.

The Senator S24L can measure in process conditions with temperatures up to +130°C / +266°F and pressures up to 16 barg / 232 psig. The antenna options permit to measure distances up to 100 m / 328 ft. The device can be installed in high nozzles ( $\leq 1$  m / 3.28 ft) when it is fitted with antenna extensions.

#### Senator S24C Radar (24 GHz) for agitated and corrosive liquids



This 24 GHz FMCW radar level transmitter is designed for liquids in harsh environment like tanks with agitators containing corrosives or in non-Ex applications with extremely high process temperatures, like molten salt in solar plants (+700°C / +1292°F). For toxic and dangerous products, the use of a Metaglas® second sealing barrier is recommended.

The PTFE and PEEK Drop antennas have optional flange plate protection for corrosive media. Heating and cooling systems prevent from crystallization inside the Metallic Horn antennas. The device measures distances up to 100 m / 328 ft and can be installed in high nozzles ( $\leq 1$  m / 3.28 ft) when fitted with antenna extensions. Standard process conditions up to +200°C / 392°F; 100 barg / 1450 psig (higher on request).

### Senator S80L (80 GHz) for liquids in narrow tanks with internal obstructions



The small beam angle and negligible dead zone of this 80 GHz FMCW radar level transmitter makes it the premium choice for liquids in small and narrow tanks with internal obstructions like agitators or heating coils, as well as tanks with long nozzles. It can even measure through tank roofs made of non-conductive material (e.g. plastic, fiberglass or glass). The flush-mounted PEEK Lens antenna (no tank intrusion) is insensitive to deposit.

There is an extensive choice of process connections starting from 3/4". Flanges have an optional PEEK plate protection for corrosive tank contents. The Senator S80L operates in process conditions with temperatures up to +150°C / +302°F and pressures up to 40 barg / 580 psig. It measures distances up to 100 m / 328 ft and a 112 mm / 4.4" extension is available for high nozzles.

### Senator S80H Radar (80 GHz) for liquids with hygienic requirements



This 80 GHz FMCW radar transmitter for hygienic liquid applications in the pharmaceutical, food and beverage industries is CIP-SIP suitable and offers a large choice of hygienic process connections: Tri-Clamp®, Tuchenhagen VARIVENT®, SMS, DIN 11851, DIN 11864-1 Form A, NEUMO BioControl®.

The small dead zone and beam angle of its flush-mounted Lens antenna enables precise measurement even in small and narrow tanks with agitators. The Senator S80H measures up to 50 m / 164 ft in process conditions up to +150°C / +302°F and 25 barg / 363 psig.

### Senator S24S Radar (24 GHz) for solids from granulates to rocks



By combining high signal dynamics and FMCW radar technology, this market-entry 24 GHz radar device measures accurately and reliably the level of solids like stone, plastic granulates or coffee beans. No need for expensive antenna aiming kits or purging systems; the proven Drop antenna design minimizes scaling and is not affected by the angle of repose.

It operates in process conditions with temperatures up to +130°C / +266°F and pressures up to 16 barg / 232 psig. The antenna options permit the device to measure distances up to 100 m / 328 ft.

### Senator S80L Radar (80 GHz) for powders and dusty atmosphere



Accurate continuous level measurement of fine powders has to deal with a series of issues like dust, low-reflective media, build-up and uneven surfaces. The specific algorithms and high signal dynamics of this 80 GHz FMCW radar transmitter are the key to provide reliable and accurate readings despite these difficult conditions. Thanks to the small beam angle of the flush-mounted Lens antenna, this powerful device handles high and narrow silos even in the presence of internal obstructions.

The Senator S80L operates in process conditions with temperatures up to +200°C / +392°F and pressures up to 40 barg / 580 psig. It offers an extensive choice of threaded ( $\geq 1\frac{1}{2}$ "") and flanged ( $\geq \text{DN}50 / 2$ "") process connections. The antenna options permit the device to measure distances up to 100 m / 328 ft. A 112 mm / 4.4" extension is available for high nozzles.

### 1.4 Measuring principle

A radar signal is emitted via an antenna, reflected from the product surface and received after a time  $t$ . The radar principle used is FMCW (Frequency Modulated Continuous Wave).

The FMCW-radar transmits a high frequency signal whose frequency increases linearly during the measurement phase (called the frequency sweep). The signal is emitted, reflected on the measuring surface and received with a time delay,  $t$ . Delay time,  $t=2d/c$ , where  $d$  is the distance to the product surface and  $c$  is the speed of light in the gas above the product.

For further signal processing the difference  $\Delta f$  is calculated from the actual transmitted frequency and the received frequency. The difference is directly proportional to the distance. A large frequency difference corresponds to a large distance and vice versa. The frequency difference  $\Delta f$  is transformed via a Fast Fourier Transform (FFT) into a frequency spectrum and then the distance is calculated from the spectrum. The level results from the difference between the tank height and the measured distance.

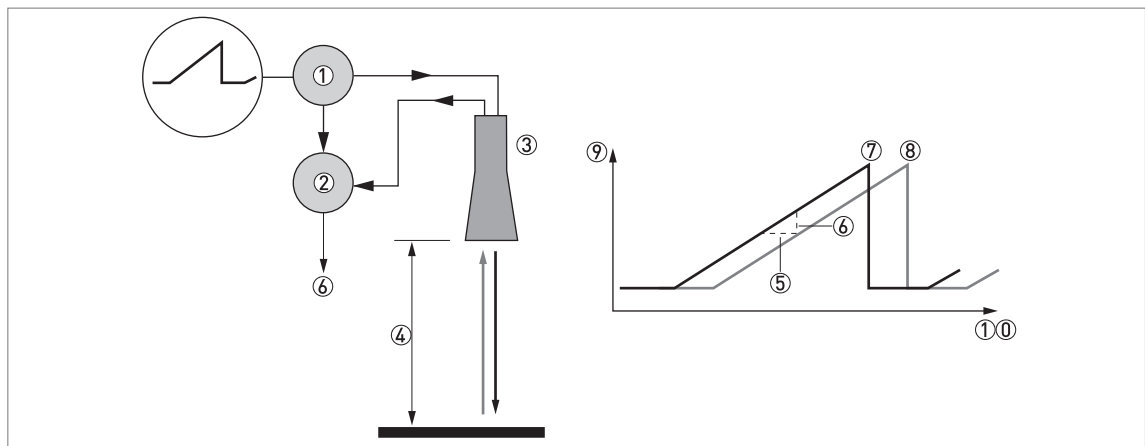

Figure 1-1: Measuring principle of FMCW radar

- ① Transmitter
- ② Mixer
- ③ Antenna
- ④ Distance to product surface, where change in frequency is proportional to distance
- ⑤ Differential time delay,  $\Delta t$
- ⑥ Differential frequency,  $\Delta f$
- ⑦ Frequency transmitted
- ⑧ Frequency received
- ⑨ Frequency
- ⑩ Time



## Measurement modes

### "Direct" mode

If the dielectric constant of the liquid is high ( $\epsilon_r \geq 1.4$ ), the level signal is the reflection on the surface of the liquid.

### "TBF Auto" mode

If the dielectric constant of the liquid is low ( $\epsilon_r$  1.4...1.5, for long-distance measurement), you must use "TBF Auto" mode to measure level correctly. "TBF Auto" is an automatic mode that lets the device make a selection between "Direct" mode and "TBF" mode. If the device finds a large radar reflection above the "tank bottom area" (the bottom 20% of the tank height), the device will use "Direct" mode. If the device finds a large radar reflection in the "tank bottom area", the device uses TBF mode. This mode can be used only in tanks with flat bottoms or in stilling wells with a reference plate at the bottom.

### "Full TBF" mode

TBF = Tank Bottom Following. If the dielectric constant of the liquid is very low ( $\epsilon_r < 1.4$ ), you must use "TBF Full" mode to measure level correctly. The device uses the radar reflection on the bottom of the tank (the signal goes through the liquid). This mode can be used only in tanks with flat bottoms or in stilling wells with a reference plate at the bottom.

## 2.1 Technical data

- *The following data is provided for general applications. If you require data that is more relevant to your specific application, please contact us or your local sales office.*
- *Additional information (certificates, special tools, software,...) and complete product documentation can be downloaded free of charge from the website.*

### Measuring system

Measuring principle	2-wire loop-powered level transmitter; FMCW radar
Frequency range	W-band (78...82 GHz)
Max. radiated power (EIRP)	< -41.3 dBm according to ETSI EN 307 372 (TLPR) and ETSI EN 302 729 (LPR)
Application range	Level measurement of liquids, pastes and slurries in hygienic applications
Primary measured value	Distance and reflection
Secondary measured value	Level, volume and mass

### Design

Construction	The measurement system consists of a measuring sensor (antenna) and a signal converter
Options	Integrated LCD display (-20...+70°C / -4...+158°F); if the ambient temperature is not in these limits, then this condition can stop the display
	Weather protection
Max. measuring range (antenna)	Lens, DN25 (1"): 25 m / 82 ft
	Lens, DN40 (1½"): 50 m / 164 ft
	Refer also to "Measuring accuracy" on page 16
Min. tank height	0.2 m / 8"
Recommended minimum blocking distance	Lens, DN25 (1"): 0.1 m / 4"
	Lens, DN40 (1½"): 0.2 m / 8"
Min. distance for reflection measurement	1 m / 3.3 ft
Beam angle (antenna)	Lens, DN25 (1"): 10°
	Lens, DN40 (1½"): 8°
<b>Display and user interface</b>	
Display	Backlit LCD display
	128 × 64 pixels in 64-step greyscale with 4-button keypad
Interface languages	English, French, German, Italian, Spanish, Portuguese, Chinese (simplified), Japanese, Russian, Czech, Polish and Turkish

### Measuring accuracy

Resolution	1 mm / 0.04"
Repeatability	±1 mm / ±0.04"
Accuracy	±2 mm / ±0.08", when distance ≤ 10 m / 33 ft; ±0.02% of measured distance, when distance > 10 m / 33 ft. For more data, refer to <i>Measuring accuracy</i> on page 16.
Digital temperature drift	Max. ±10 mm / ±0.39" for the full temperature range
<b>Reference conditions acc. to EN 61298-1</b>	
Temperature	+15...+25°C / +59...+77°F
Pressure	1013 mbara ±50 mbar / 14.69 psia ±0.73 psi
Relative air humidity	60% ±15%
Target	Metal plate in an anechoic chamber

### Operating conditions

<b>Temperature</b>	
Ambient temperature	-40...+80°C / -40...+176°F Integrated LCD display: -20...+70°C / -5...+140°F; if the ambient temperature is not in these limits, the display switches off. The device continues to operate correctly. Ex: see supplementary operating instructions or approval certificates.
Relative humidity	0...99%
Storage temperature	-40...+85°C / -40...+185°F
Process connection temperature (higher temperature on request)	-40...+150°C / -40...+302°F (the process connection temperature must agree with the temperature limits of the gasket material. Refer to "Materials" in this table.) Ex: see supplementary operating instructions or approval certificates
<b>Pressure</b>	
Process pressure	DN25 (1") Lens antenna with DN50 VARIVENT® Type N connection -1...10 barg / -14.5...145 psig
	DN25 (1") Lens antenna and DN40 (1½") Lens antenna with all process connections except the DN50 VARIVENT® Type N -1...25 barg / -14.5...363 psig
<b>Other conditions</b>	
Dielectric constant {ε <sub>r</sub> }	Direct mode: ≥1.4 TBF mode: ≥1.1
Ingress protection	IEC 60529: IP66 / IP68 (0.1 barg / 1.45 psig)
	NEMA 250: NEMA type 4X - 6 (housing) and type 6P (antenna)
Maximum rate of change	60 m/min / 196 ft/min

### Installation conditions

Process connection position	Make sure that there are not any obstructions directly below the process connection for the device. For more data, refer to <i>Installation</i> on page 24.
Dimensions and weights	For dimensions and weights data refer to <i>Dimensions and weights</i> on page 20.

## Materials

Housing	Standard: Polyester-coated aluminium
	Option: Stainless steel (1.4404 / 316L) – non-Ex devices only. Ex approvals will be available in the second quarter of 2018.
Wetted materials	PEEK Victrex 450G and stainless steel (1.4404 / 316L)
Surface roughness of wetted parts	Ra < 0.8 µm / 32 µin – AARH
Gaskets	BioControl®: EPDM (-20°C...+150°C / -4...+302°F) SMS, Tri-Clamp®, VARIVENT®, DIN 11851, DIN 11864-1: without ①
Cable gland	Standard: none
	Options: Plastic (Non-Ex: black, Ex i-approved: blue); nickel-plated brass; stainless steel; M12 (4-pin connector)
Weather protection (Option)	Stainless steel (1.4404 / 316L)

## Process connections

For DN25/1" Lens antenna	Tri-Clamp® 1½" or 2"; DIN 11851 DN40 or DN50; DIN 11864-1 DN40 or DN50; SMS 51; VARIVENT® Type N (DN50); others on request
For DN40/1½" Lens antenna	BioControl® DN50; Tri-Clamp® 2"; others on request

## Electrical connections

Power supply	<b>Terminals output – Non-Ex / Ex i:</b> 12...30 V DC; min./max. value for an output of 21.5 mA at the terminals
	<b>Terminals output – Ex d:</b> 16...36 V DC; min./max. value for an output of 21.5 mA at the terminals
Maximum current	21.5 mA
Current output load	<b>Non-Ex / Ex i:</b> $R_L [\Omega] \leq ((U_{ext} - 12 V)/21.5 \text{ mA})$ . For more data, refer to <i>Minimum power supply voltage</i> on page 18.
	<b>Ex d:</b> $R_L [\Omega] \leq ((U_{ext} - 16 V)/21.5 \text{ mA})$ . For more data, refer to <i>Minimum power supply voltage</i> on page 18.
Cable entry	Standard: M20×1.5; Options: ½ NPT; 4-pin male M12 connector
Cable gland	Standard: none
	Options: M20×1.5 (cable diameter: 7...12 mm / 0.28...0.47"); others are available on request
Cable entry capacity (terminal)	0.5...3.31 mm <sup>2</sup> [AWG 20...12]

## Input and output

<b>Current output</b>	
Output signal	Standard: 4...20 mA
	Options: 3.8...20.5 mA acc. to NAMUR NE 43; 4...20 mA (reversed); 3.8...20.5 mA (reversed) acc. to NAMUR NE 43
Output type	Passive
Resolution	±5 µA
Temperature drift	Typically 50 ppm/K
Error signal	High: 21.5 mA; Low: 3.5 mA acc. to NAMUR NE 43
<b>HART®</b>	
Description	Digital signal transmitted with the current output signal (HART® protocol) ②
Version	7.4
Load	≥ 250 Ω

Digital temperature drift	Max. $\pm 15$ mm / 0.6" for the full temperature range
Multi-drop operation	Yes. Current output = 4 mA. Enter Program mode to change the polling address (1...63).
Available drivers	FC475, AMS, PDM, FDT/DTM
<b>PROFIBUS PA</b> (pending)	
Type	PROFIBUS MBP interface that agrees with IEC 61158-2 with 31.25 kbit/s; voltage mode (MBP = Manchester-Coded, Bus-Powered)
Function blocks	1 $\times$ Transducer Block Level (TB-Level), 1 $\times$ Physical Block (PB), 4 $\times$ Analog Input Block (AI), 1 $\times$ Totalizer Function Block (TOT)
Device power supply	9...32 V DC – bus powered; no additional power supply required
Polarity sensitivity	No
Basic current	18 mA
<b>FOUNDATION™ fieldbus</b> (pending)	
Physical layer	FOUNDATION™ fieldbus protocol that agrees with IEC 61158-2 and FISCO model; galvanically isolated
Communication standard	H1
ITK version	6.3
Function blocks	1 $\times$ Enhanced Resource Block (RB), 1 $\times$ Customer Level Transducer Block (LEVELTB), 1 $\times$ Customer Converter Transducer Block (CONVTB), 1 $\times$ Customer Diagnosis Transducer Block (DIAGTB), 4 $\times$ Analog Input Block (AI), 1 $\times$ Digital Input (DI), 1 $\times$ Integrator Block (IT), 1 $\times$ Proportional Integral Derivate Block (PID), 1 $\times$ Arithmetic Block (AR)
	Analog Input Block: 10 ms
	Digital Input Block: 20 ms
	Integrator Block: 15 ms
	Proportional Integral Derivate Block: 25 ms
Device power supply	Not intrinsically safe: 9...32 V DC Intrinsically safe: 9...24 V DC
Basic current	18 mA
Maximum error current FDE	25.5 mA (= basic current + error current = 18 mA + 7.5 mA)
Polarity sensitivity	No
Minimum cycle time	250 ms
Output data	Level, distance, volume, ullage volume, mass, ullage mass
Input data	None
Link Active Scheduler	Supported
NAMUR NE 107 data	Supported with FF field diagnosis (FF-891)

### Approvals and certification

CE	The device meets the essential requirements of the EU Directives. The manufacturer certifies successful testing of the product by applying the CE marking.
	For more data about the EU Directives and European Standards related to this device, refer to the EU Declaration of Conformity. You can download this document free of charge from the website.
Conformity to sanitary regulations	Regulation (EC) No 1935/2004, Commission Regulation (EC) No 2023/2006, Commission Regulation (EU) No 10/2011
	FDA 21 CFR 177.2600 and CFR 177.2415
Vibration resistance	EN 60068-2,64 and EN 60721-3-4 (1...9 Hz: 3 mm / 10...200 Hz: 1g; 10g shock ½ sinus: 11 ms)

<b>Explosion protection</b>	
ATEX (EU Type Approval) - pending	II 1/2 G Ex ia IIC T6...T3 Ga/Gb;
	II 1/2 D Ex ia IIIC T85°C...T150°C Da/Db;
	II 1/2 G Ex db ia IIC T6...T3 Ga/Gb;
	II 1/2 D Ex ia tb IIIC T85°C...T150°C Da/Db
ATEX (Type Approval) - pending	II 3 G Ex ic IIC T6...T3 Gc;
	II 3 D Ex ic IIIC T85°C...T150°C Dc
IECEX - pending	Ex ia IIC T6...T3 Ga/Gb;
	Ex ia IIIC T85°C...T150°C Da/Db;
	Ex db ia IIC T6...T3 Ga/Gb;
	Ex ia tb IIIC T85°C...T150°C Da/Db;
	Ex ic IIC T6...T3 Gc;
	Ex ic IIIC T85°C...T150°C Gc
cQPSus - pending	<b>Division ratings</b>
	XP-IS, Class I, Div 1, GPS ABCD, T6...T3;
	DIP, Class II, III, Div 1, GPS EFG, T85°C...T150°C;
	IS, Class I, Div 1, GPS ABCD, T6...T3;
	IS, Class II, III, Div 1, GPS EFG, T85°C...T150°C;
	NI, Class I, Div 2, GPS ABCD, T6...T3;
	NI, Class II, III, Div 2, GPS FG, T85°C...T150°C
	<b>Zone ratings</b>
	Class I, Zone 1, AEx db ia [ia Ga] IIC T6...T3 Gb (US) – antenna suitable for Zone 0; Ex db ia [ia Ga] IIC T6...T3 Gb (Canada) – antenna suitable for Zone 0;
	Class I, Zone 0, AEx ia IIC T6...T3 Ga (US); Ex ia IIC T6...T3 Ga (Canada);
	Zone 20, AEx ia IIIC T85°C...T150°C Da (US); Ex ia IIIC T85°C...T150°C Da (Canada);
	Zone 21, AEx ia tb [ia Da] IIIC T85°C...T150°C Db (US) – antenna suitable for Zone 20; Ex ia tb [ia Da] IIIC T85°C...T150°C Db (Canada) – antenna suitable for Zone 20
	NEPSI - pending
Ex d ia IIC T3~T6 Ga/Gb;	
Ex iaD 20/21 T85...T150;	
Ex iaD 20/21 tD A21 IP6X T85°C...T150°C	
<b>Hygienic</b>	
3-A®	For Tri-Clamp®
EHEDG	For VARIVENT® Type N, Tri-Clamp®, DIN 11851 and DIN 11864-1 when fitted with an alternative gasket (which agrees with EHEDG Position paper "Easy cleanable pipe couplings and process connections" Version 3, December 2015).

<b>Other standards and approvals</b>	
Electromagnetic compatibility	<b>EU:</b> Electromagnetic Compatibility directive (EMC)
Radio approvals	<b>EU:</b> Radio Equipment directive (RED)
	<b>FCC Rules:</b> Part 15
	<b>Industry Canada:</b> RSS-211
Electrical safety	<b>EU:</b> Agrees with the safety part of the Low Voltage directive (LVD)
	<b>USA and Canada:</b> Agrees with NEC and CEC requirements for installation in ordinary locations
NAMUR	NAMUR NE 21 Electromagnetic Compatibility (EMC) of Industrial Process and Laboratory Control Equipment
	NAMUR NE 43 Standardization of the Signal Level for the Failure Information of Digital Transmitters
	NAMUR NE 53 Software and Hardware of Field Devices and Signal Processing Devices with Digital Electronics
	NAMUR NE 107 Self-Monitoring and Diagnosis of Field Devices

① Tri-Clamp® is a registered trademark of Ladish Co., Inc.. BioControl® is a registered trademark of Neumo-Ehrenberg-Group.  
 VARIVENT® is a registered trademark of GEA Tuchenhausen GmbH.

② HART® is a registered trademark of the HART Communication Foundation

## 2.2 Measuring accuracy

Use these graphs to find the measuring accuracy for a given distance from the transmitter.

### DN25 (1") Lens antenna

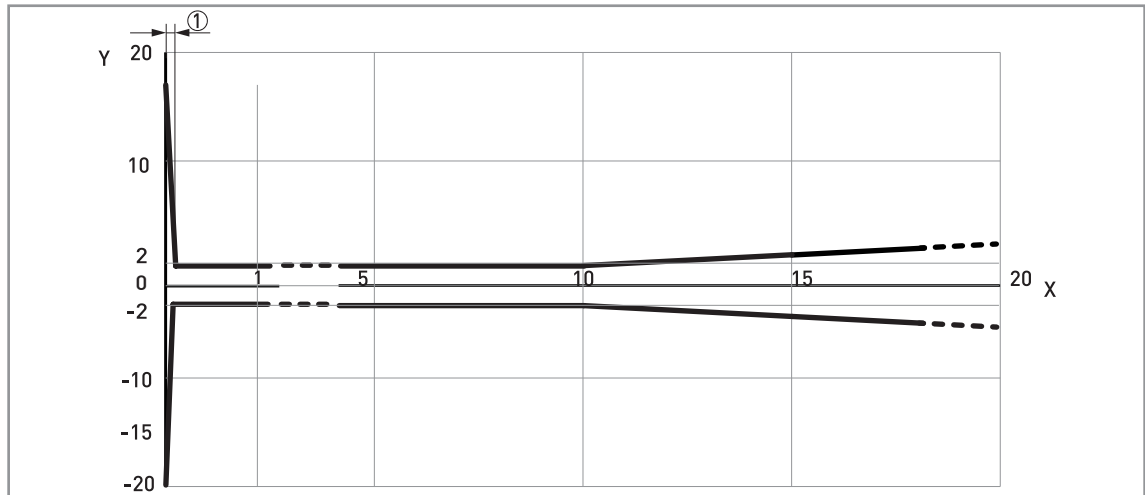

Figure 2-1: DN25 (1") Lens antenna: measuring accuracy (graph of measuring accuracy in mm against measuring distance in m)

X: Measuring distance from the thread stop or flange facing of the process connection [m]

Y: Measuring accuracy [+yy mm / -yy mm]

① 100 mm

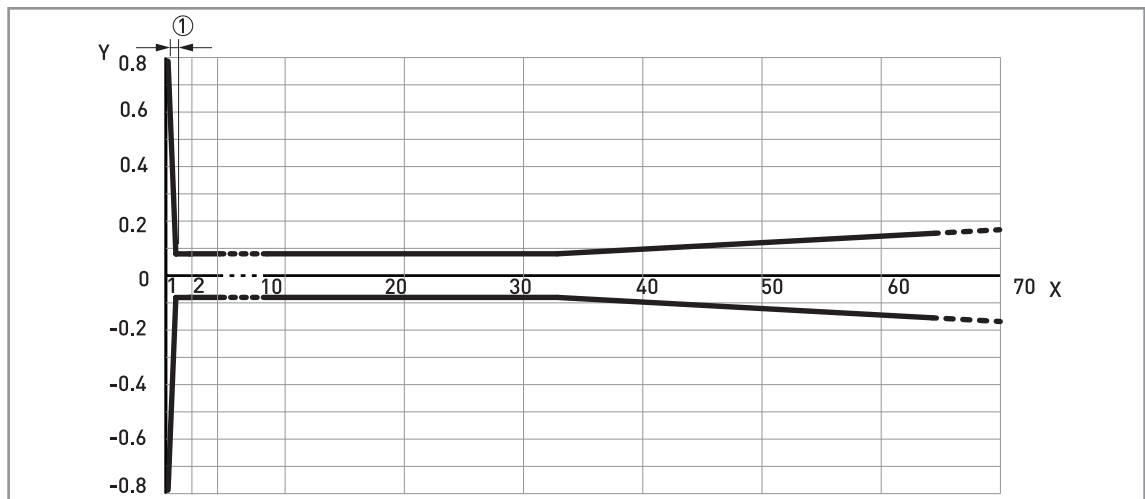

Figure 2-2: DN25 (1") Lens antenna: measuring accuracy (graph of measuring accuracy in inches against measuring distance in ft)

X: Measuring distance from the thread stop or flange facing of the process connection [ft]

Y: Measuring accuracy [+yy inches / -yy inches]

① 3.94"

*To calculate the accuracy at a given distance from the antenna, refer to Technical data on page 10 (measuring accuracy).*



DN40 (1½") Lens antenna

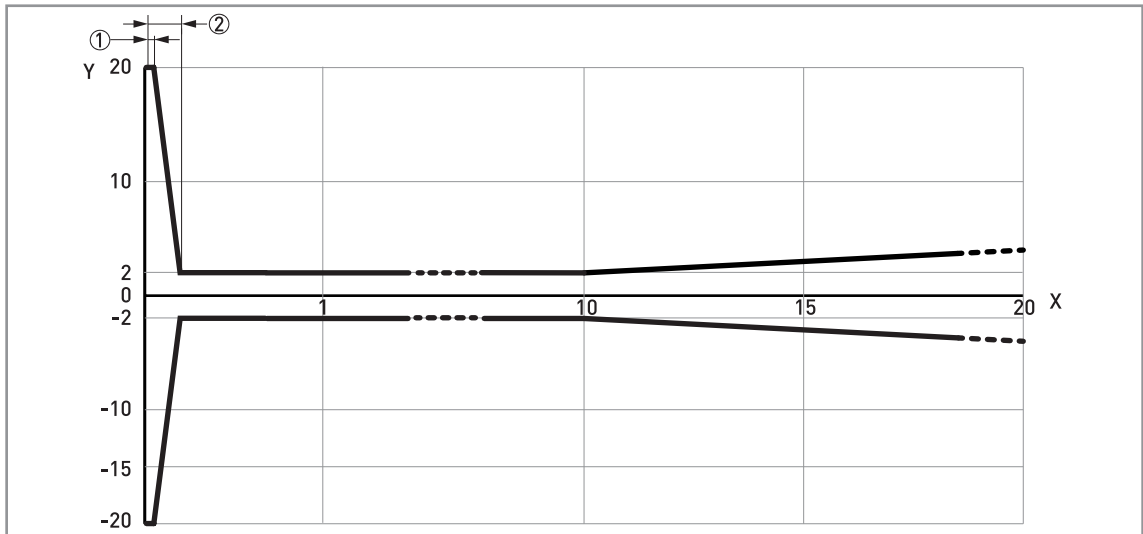

Figure 2-3: DN40 (1½") Lens antenna: measuring accuracy (graph of measuring accuracy in mm against measuring distance in m)

X: Measuring distance from the thread stop or flange facing of the process connection [m]

Y: Measuring accuracy [+yy mm / -yy mm]

① 50 mm

② 200 mm

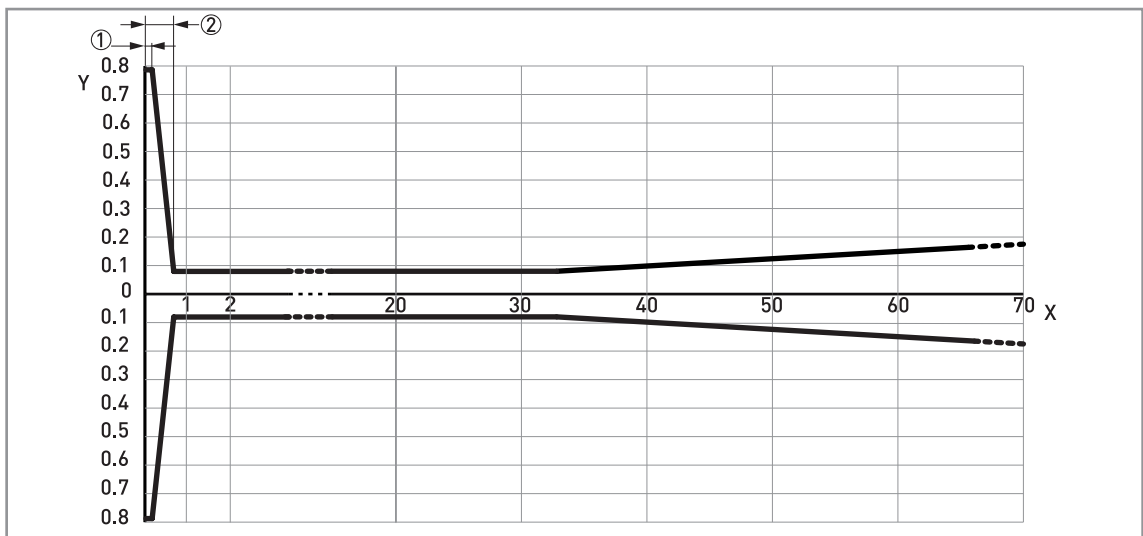

Figure 2-4: DN40 (1½") Lens antenna: measuring accuracy (graph of measuring accuracy in inches against measuring distance in ft)

X: Measuring distance from the thread stop or flange facing of the process connection [ft]

Y: Measuring accuracy [+yy inches / -yy inches]

① 1.97"

② 7.87"

To calculate the accuracy at a given distance from the antenna, refer to Technical data on page 10 (measuring accuracy).

### 2.3 Minimum power supply voltage

Use these graphs to find the minimum power supply voltage for a given current output load.

#### Non-Ex and Hazardous Location approved (Ex i / IS) devices

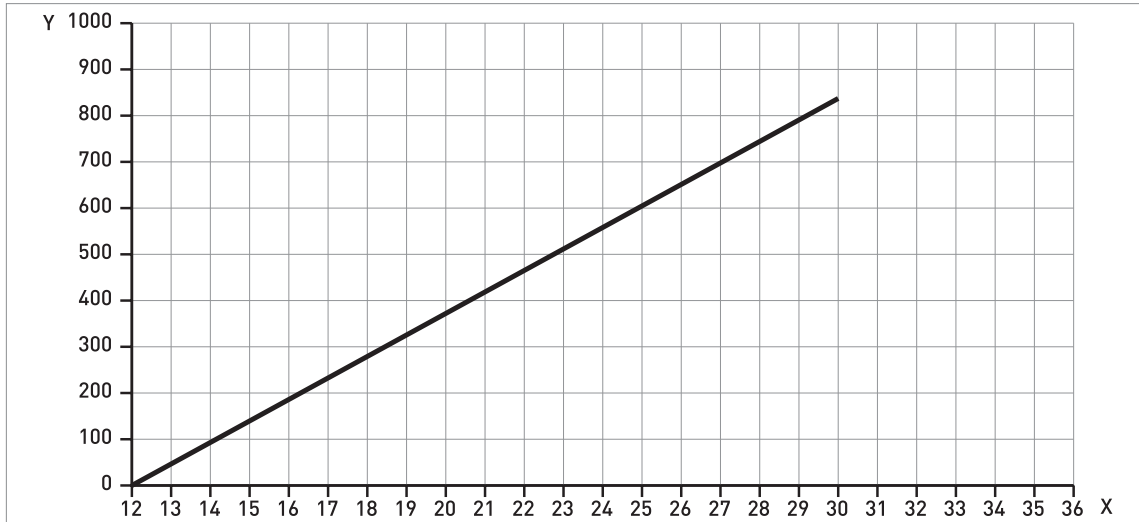

Figure 2-5: Minimum power supply voltage for an output of 21.5 mA at the terminals (Non-Ex and Hazardous Location approval (Ex i / IS))

X: Power supply U [V DC]  
 Y: Current output load  $R_L$  [ $\Omega$ ]

Hazardous Location (Ex d / XP/NI) approved devices

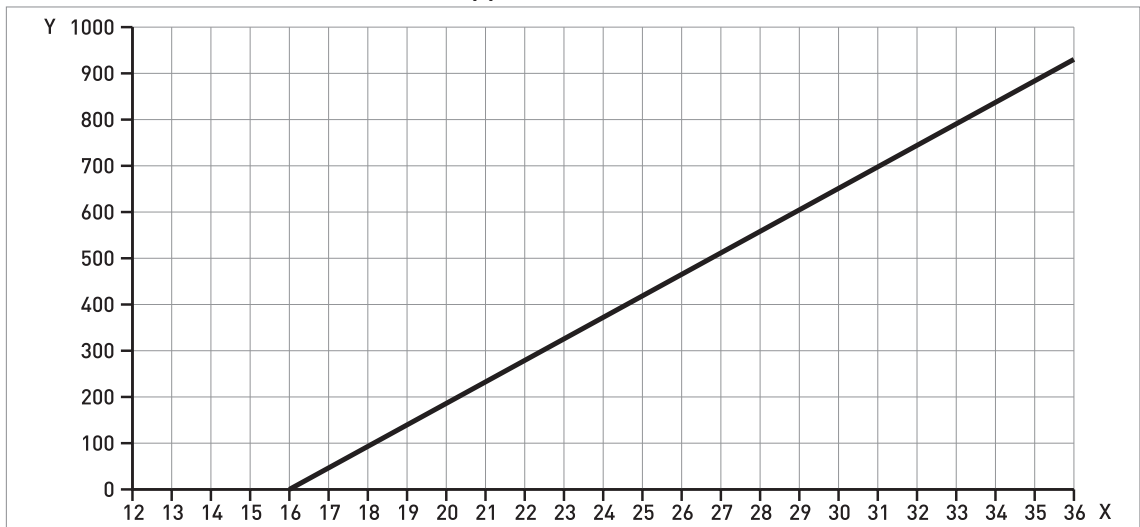

Figure 2-6: Minimum power supply voltage for an output of 21.5 mA at the terminals (Hazardous Location approval [Ex d / XP/NI])

X: Power supply U [V DC]  
 Y: Current output load  $R_L$  [ $\Omega$ ]

## 2.4 Dimensions and weights

## DN25 / 1" Lens antenna versions

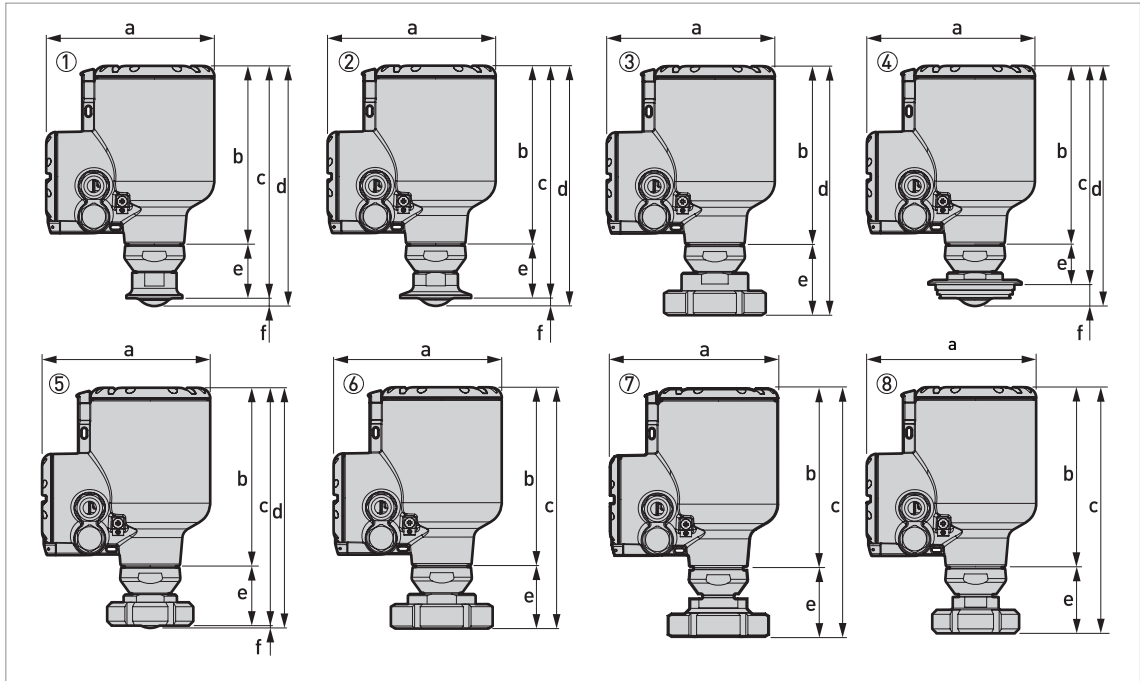

Figure 2-7: DN25 / 1" Lens antenna versions

- ① DN25 / 1" Lens antenna with 1½" Tri-Clamp® connection
- ② DN25 / 1" Lens antenna with 2" Tri-Clamp® connection
- ③ DN25 / 1" Lens antenna with SMS 1145 (51) connection
- ④ DN25 / 1" Lens antenna with VARIVENT® connection
- ⑤ DN25 / 1" Lens antenna with DN40 DIN 11851 connection
- ⑥ DN25 / 1" Lens antenna with DN50 DIN 11851 connection
- ⑦ DN25 / 1" Lens antenna with DN50 DIN 11864-1 connection
- ⑧ DN25 / 1" Lens antenna with DN40 DIN 11864-1 connection

- *The diameter of the outer sheath of the cable must be 7...12 mm or 0.28...0.47".*
- *Cable glands for cQPSus-approved devices must be supplied by the customer.*
- *A weather protection cover is available as an accessory with all devices.*

DN25 / 1" Lens antenna: Dimensions in mm

Type of process connection	Dimensions [mm]					
	a	b	c	d	e	f
1½" Tri-Clamp®	151	160	209	216	48.7	7
2" Tri-Clamp®	151	160	209	216	48.7	11
SMS 1145	151	160	224	—	63.4	—
VARIVENT®	151	160	209	216	48.6	7
DN40 DIN 11851	151	160	214	216	53.6	2.1
DN50 DIN 11851	151	160	217	—	56.7	—
DN50 DIN 11864-1	151	160	222.8	—	62.5	—
DN40 DIN 11864-1	151	160	219.8	—	59.4	—

DN25 / 1" Lens antenna: Dimensions in inches

Type of process connection	Dimensions [inches]					
	a	b	c	d	e	f
1½" Tri-Clamp®	5.94	6.30	8.23	8.50	1.92	0.28
2" Tri-Clamp®	5.94	6.30	8.23	8.50	1.92	0.43
SMS 1145	5.94	6.30	8.82	—	2.50	—
VARIVENT®	5.94	6.30	8.23	8.50	1.91	0.28
DN40 DIN 11851	5.94	6.30	8.43	8.50	2.11	0.08
DN50 DIN 11851	5.94	6.30	8.54	—	2.23	—
DN50 DIN 11864-1	5.94	6.30	8.77	—	2.46	—
DN40 DIN 11864-1	5.94	6.30	8.65	—	2.34	—

DN40 / 1½" Lens antenna versions

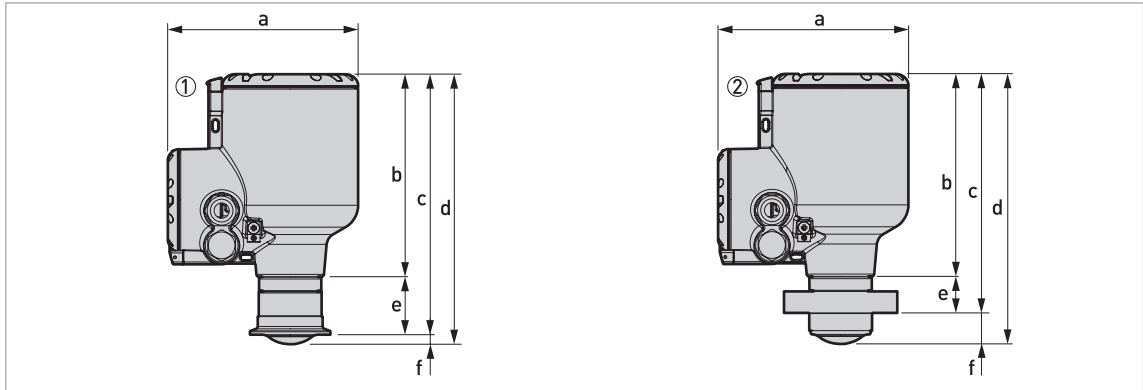

Figure 2-8: DN40 / 1½" Lens antenna versions

- ① DN40 / 1½" Lens antenna with 2" Tri-Clamp® connection
- ② DN40 / 1½" Lens antenna with DN50 NEUMO BioControl® connection

- The diameter of the outer sheath of the cable must be 7...12 mm or 0.28...0.47".
- Cable glands for cQPSus-approved devices must be supplied by the customer.
- A weather protection cover is available as an accessory with all devices.

DN40 / 1" Lens antenna: Dimensions in mm

Type of process connection	Dimensions [mm]					
	a	b	c	d	e	f
2" Tri-Clamp®	151	160	209	216	48.7	11
DN50 NEUMO BioControl®	151	160	189.3	213.8	28.9	24.6

DN40 / 1" Lens antenna: Dimensions in inches

Type of process connection	Dimensions [inches]					
	a	b	c	d	e	f
2" Tri-Clamp®	5.94	6.30	8.23	8.50	1.92	0.43
DN50 NEUMO BioControl®	5.94	6.30	7.45	8.41	1.14	0.97

**Weather protection option**

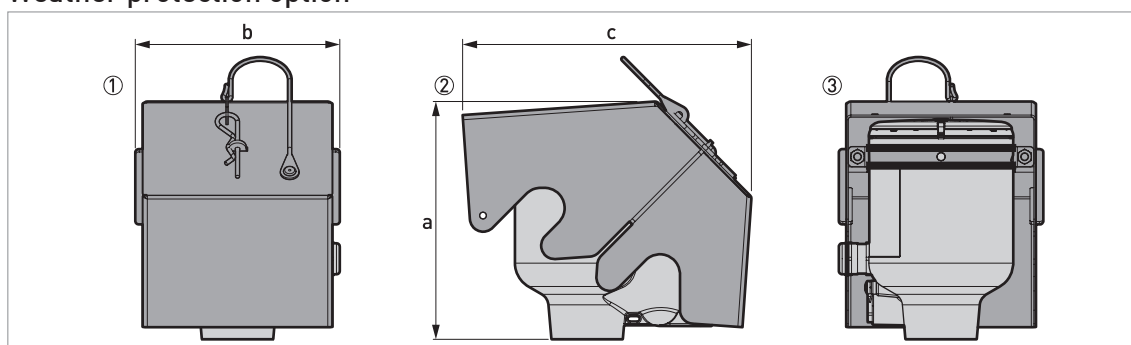

**Figure 2-9: Weather protection option**

- ① Front view (with weather protection closed)
- ② Left side (with weather protection closed)
- ③ Rear view (with weather protection closed)

**Weather protection: Dimensions and weights**

	Dimensions						Weights [kg]	
	a		b		c		[kg]	[lb]
	[mm]	[inch]	[mm]	[inch]	[mm]	[inch]		
Weather protection	177	6.97	153	6.02	216	8.50	1.3	2.9

**Converter weight**

Type of housing	Weights	
	[kg]	[lb]
Compact aluminium housing	2.1	4.6
Compact stainless steel housing	4.5	9.9

**Antenna option weights**

Antenna options	Min./Max. weights	
	[kg]	[lb]

**Standard options, with converter**

DN25 (1") Lens antenna with 1.5" Tri-Clamp® connection	2.8	6.2
DN25 (1") Lens antenna with 2" Tri-Clamp® connection	2.8	6.2
DN25 (1") Lens antenna with DN40 DIN11851 connection	2.9	6.4
DN25 (1") Lens antenna with DN50 DIN11851 connection	3.2	7.1
DN25 (1") Lens antenna with DN51 SMS1145 connection	3.2	7.1
DN25 (1") Lens antenna with DN50 VARIVENT® Type N connection	2.9	6.4
DN25 (1") Lens antenna with DN40 DIN11864-1 connection	2.9	6.4
DN25 (1") Lens antenna with DN50 DIN11864-1 connection	3.2	7.1
DN40 (1½") Lens antenna with DN50 NEUMO BioControl® connection	2.9	6.4
DN40 (1½") Lens antenna with 2" Tri-Clamp® connection	2.4	5.3

### 3.1 Intended use

*Responsibility for the use of the measuring devices with regard to suitability, intended use and corrosion resistance of the used materials against the measured fluid lies solely with the operator.*

*The manufacturer is not liable for any damage resulting from improper use or use for other than the intended purpose.*

This radar level transmitter measures distance, level, mass, volume and reflectivity of liquids, pastes and slurries.

It can be installed on tanks for hygienic applications.

### 3.2 Pre-installation requirements

*Obey the precautions that follow to make sure that the device is correctly installed.*

- Make sure that there is sufficient space on all sides.
- Protect the signal converter from direct sunlight. If necessary, install the weather protection accessory.
- Do not subject the signal converter to heavy vibrations. The devices are tested for vibration and agree with EN 50178 and IEC 60068-2-6.



### 3.3 Installation

#### 3.3.1 Pressure and temperature ranges

The process connection temperature range must agree with the temperature limits of the gasket material. The operating pressure range is subject to the process connection used and the flange temperature.

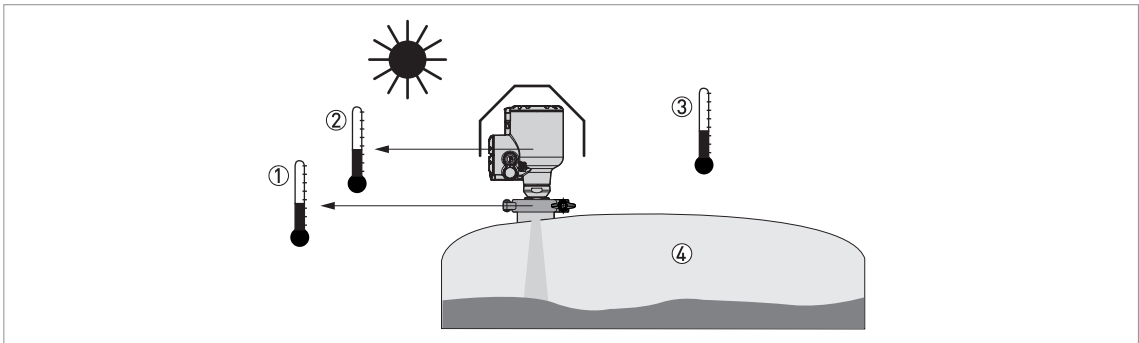

Figure 3-1: Pressure and temperature ranges

- ① Temperature at the process connection  
 Non-Ex devices: The temperature range depends on the type of antenna, process connection and the seal material. Refer to the table that follows.  
 Devices with Hazardous Location approvals: see supplementary instructions
- ② Ambient temperature for operation of the display  
 -20...+70°C / -4...+158°F  
 If the ambient temperature is not between these limits, then it is possible that the display screen will not operate temporarily. The device continues to measure level and send an output signal.
- ③ Ambient temperature  
 Non-Ex devices: -40...+80°C / -40...+176°F  
 Devices with Hazardous Location approvals: see supplementary instructions
- ④ Process pressure  
 Depends on the type of antenna and process connection. Refer to the table that follows.

#### Maximum process connection temperature and operating pressure

Antenna type	Options	Maximum process connection temperature		Maximum operating pressure	
		[°C]	[°F]	[barg]	[psig]
Lens DN25, PEEK	DN50 VARIVENT® Type N adaptor	+150	+302	10	145
Lens DN25, PEEK	DN50 DIN 11851 adaptor; SMS 51	+150	+302	25	362
Lens DN25, PEEK	DN40 DIN 11851 adaptor; DIN 11864-1; Tri-Clamp®	+150	+302	40	580
Lens DN40, PEEK	2" Tri-Clamp®; DN50 NEUMO BioControl®	+150	+302	40	580

### 3.3.2 Recommended mounting position

Follow these recommendations to make sure that the device measures correctly. They have an effect on the performance of the device.

We recommend that you prepare the installation when the tank is empty.

#### Recommended nozzle position for liquids, pastes and slurries

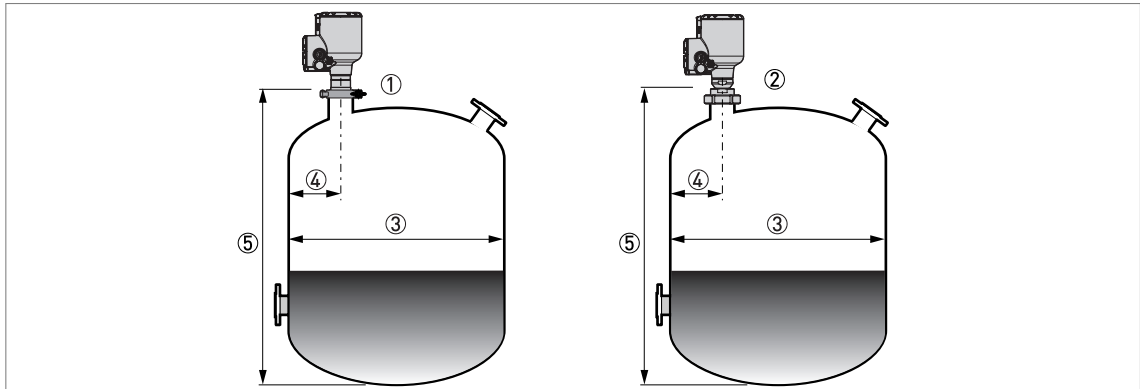

Figure 3-2: Recommended nozzle position for liquids, pastes and slurries

- ① Socket for the DN25 Lens antenna
- ② Socket for the DN40 Lens antenna
- ③ Tank diameter
- ④ Minimum distance of the nozzle or socket from the tank wall (depends on the antenna type and size – refer to items ① and ② in this list):
  - DN25 Lens :  $1/5 \times$  tank height
  - DN40 Lens:  $1/10 \times$  tank height
 Maximum distance of the nozzle or socket from the tank wall (depends on the antenna type and size – refer to items ① and ② in this list):
  - Lens:  $1/3 \times$  tank diameter
- ⑤ Tank height

If there is a nozzle on the tank before installation, the nozzle must be a minimum of 200 mm / 7.9" from the tank wall. The tank wall must be flat and there must not be obstacles adjacent to the nozzle or on the tank wall.

#### Number of devices that can be operated in a tank

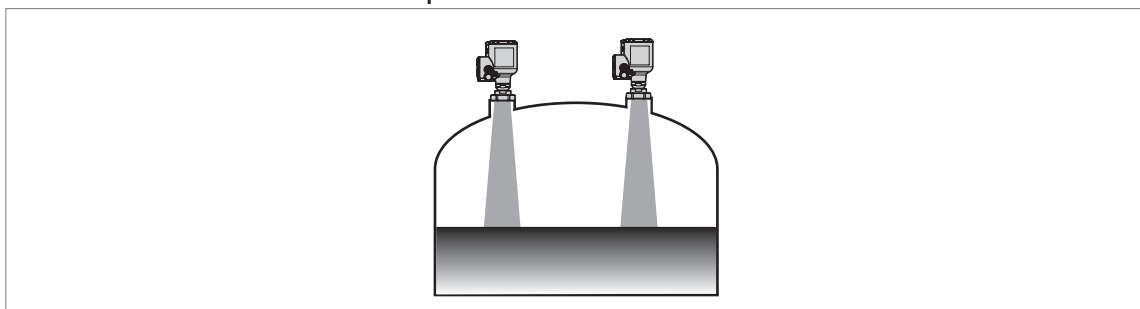

Figure 3-3: There is no maximum limit to the number of devices that can be operated in the same tank

There is no maximum limit to the number of devices that can be operated in the same tank. They can be installed adjacent to other radar level transmitters.

### 3.3.3 Mounting restrictions

#### LPR and TLPR devices

*LPR (Level Probing Radar) devices measure level in the open air or in a closed space (a metallic tank etc.). TLPR (Tank Level Probing Radar) devices measure level in a closed space only. You can use LPR devices for TLPR applications. For more data, refer to Order code on page 37, antenna options.*

#### Causes of interference signals

- Objects in the tank or pit.
- Sharp corners that are perpendicular to the path of the radar beam.
- Sudden changes in tank diameter in the path of the radar beam.

*Do not install the device above objects in the tank (agitator etc.) or pit. Objects in the tank or pit can cause interference signals. If there are interference signals, the device will not measure correctly.*

*If it is not possible to install the device on another part of the tank or pit, do an empty spectrum scan. For more data, refer to the handbook.*

#### Equipment and obstacles: how to prevent measurement of interference signals

Do not put the device immediately above equipment and obstacles in a tank or pit. This can have an effect on the performance of the device.

*If possible, do not install a nozzle on the tank centerline.*

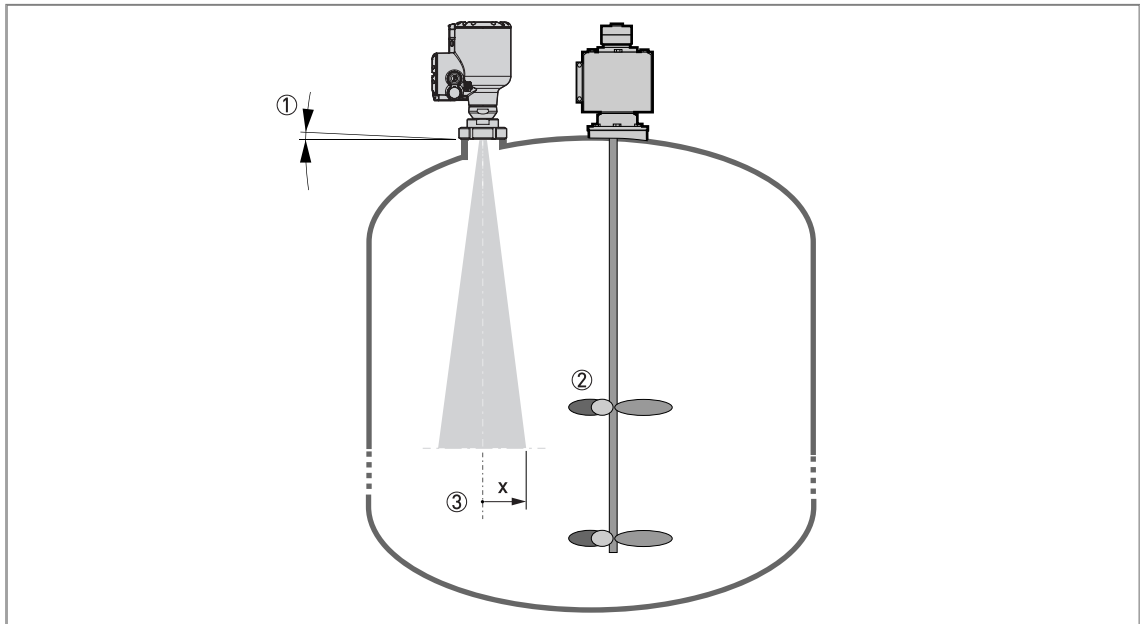

Figure 3-4: Equipment and obstacles: how to prevent measurement of interference signals

- ① Do not tilt the device more than 2°
- ② We recommend that you do an empty spectrum recording if there are too many obstacles in the radar beam (refer to the handbook).
- ③ Beam radius of the antenna: refer to the table below. The beam radius increases by increments of "x" mm for each metre of distance from the antenna.

### Beam radius of the antenna

Antenna type	Beam angle	Beam radius, x	
		[mm/m]	[in/ft]
Lens, DN25 (1")	10°	87	1.0
Lens, DN40 (1½")	8°	70	0.8

### Product inlets

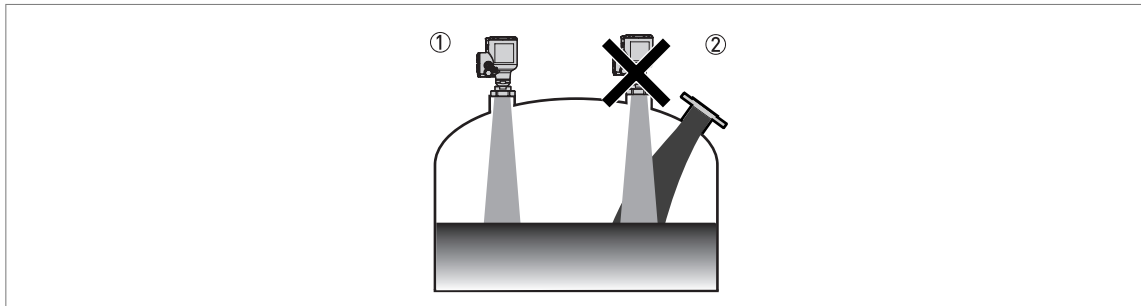

Figure 3-5: Product inlets

- ① The device is in the correct position.
- ② The device is too near to the product inlet.

*Do not put the device near to the product inlet. If the product that enters the tank touches the antenna, the device will measure incorrectly. If the product fills the tank directly below the antenna, the device will also measure incorrectly.*

*For more data about the measuring range of each type of antenna, refer to Measuring accuracy on page 16.*

## 3.3.4 Process connections

### Requirements for hygienic connections: General notes

#### **Installation conditions for EHEDG-approved devices**

- *To prevent contamination of the tank contents by microorganisms, make sure that the bottom of the antenna is flush with the inner surface of the tank.*
- *The antenna must be accessible for cleaning.*
- *Process seals must agree with EHEDG guidelines. Refer to the Position Paper of the EHEDG Test Institutes Working Group: "Easy cleanable Pipe couplings and Process connections" on this website: <https://www.ehedg.org/>. Go to Guidelines > Free Documents, find "EHEDG Position Paper" in the list of documents and make a selection from the language options.*
- *Make sure that you do not damage parts made of PEEK, polished parts and the O-ring. Use standard CIP-SIP process conditions. Make sure that the antenna, gaskets and other process seals are resistant to the tank contents and the product used for the cleaning process.*

**Installation conditions for 3-A®-approved devices**

- To prevent contamination of the tank contents by microorganisms, make sure that the bottom of the antenna is flush with the inner surface of the tank.
- Make sure that the position of the device permits liquid to drain from the antenna.
- The antenna must be accessible for cleaning.
- Process connections must agree with 3-A® Sanitary Standards. Refer to 3-A® Sanitary Standard for Sensors and Sensor Fittings and Connections, Number 74-06.
- Process seals must agree with 3-A® Sanitary Standards. Refer to 3-A® Sanitary Standard for Multiple-Use Rubber and Rubber-Like Materials Used as Product Contact Surfaces in Dairy Equipment, Number 18-03. Refer also to 3-A Sanitary Standards for Sanitary fittings, Number 63-03 and 3-A CCE Coordination Bulletin, Number 2011-3 (DIN Standard Fittings Compliance).
- Make sure that you do not damage parts made of PEEK, polished parts and the O-ring. Use standard CIP-SIP process conditions. Make sure that the antenna, gaskets and other process seals are resistant to the tank contents and the product used for the cleaning process.

**Nozzles and sockets**

To make the cleaning of the antenna easier, attach the device to a short process connection. The height of the process connection must be equal or less than its diameter.

**BioControl® (hygienic) connections: installation procedure**

Figure 3-6: BioControl® connection: installation procedure

- ① BioControl® connection on the tank
- ② Flange bolts

**Tri-Clamp® (hygienic) connections: installation procedure**

Figure 3-7: Tri-Clamp® connection: installation procedure

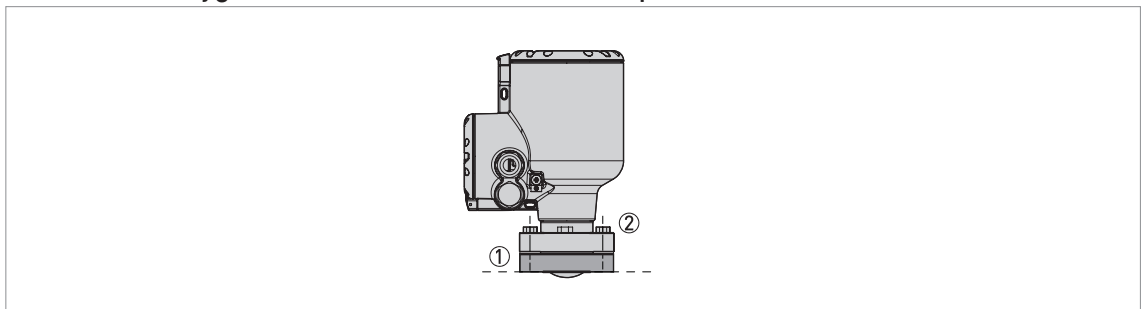
- ① Tank socket
- ② Clamp

***EHEDG-approval***

*You can only use EHEDG-approved devices that have a Tri-Clamp® connection with a Combifit T-seal.*

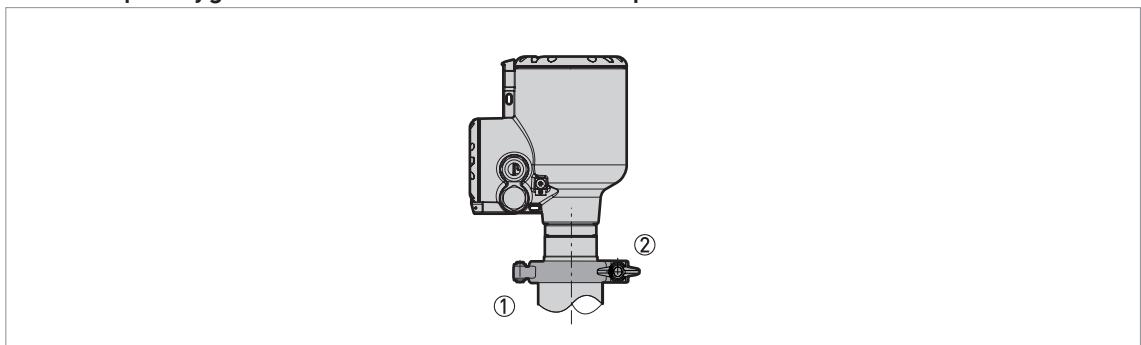
**DIN 11851 (hygienic) connections: installation procedure**

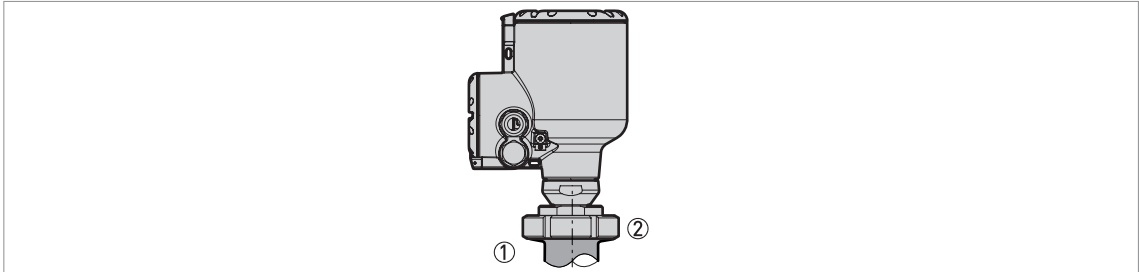

Figure 3-8: DIN 11851 connection: installation procedure

- ① Tank socket
- ② Union nut for DIN 11851 connection

*You can only use EHEDG-approved devices that have a DIN 11851 connection with:*

- *an ASEPTO-STAR, type k-flex upgrade gasket from Kieselmann GmbH, or*
- *an EPDM or FKM/FPM inner gasket from SKS B.V.*

**DIN 11864-1 (hygienic) connections: installation procedure**

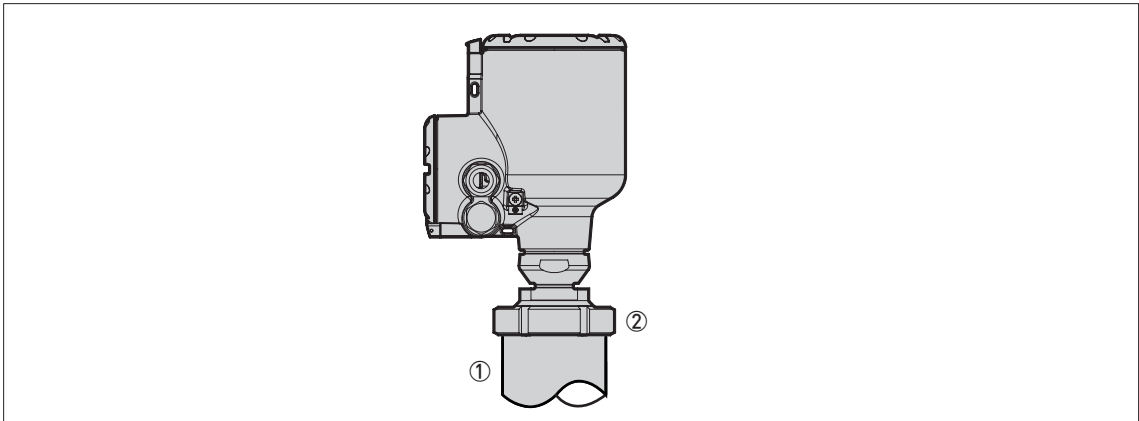

Figure 3-9: DIN 11864-1 connection: installation procedure

- ① Tank socket
- ② Union nut for DIN 11864-1 connection

*DIN 11864-1 Form A agrees with EHEDG design criteria.*

**SMS connections: installation procedure**

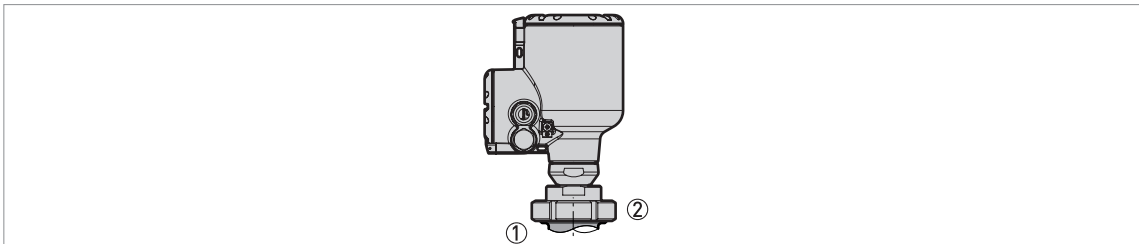

Figure 3-10: SMS connection: installation procedure

- ① Tank socket
- ② Union nut for SMS connection

*The SMS connection does not agree with 3-A® and EHEDG sanitary design standards.*

### VARIVENT® (hygienic) connections: installation procedure

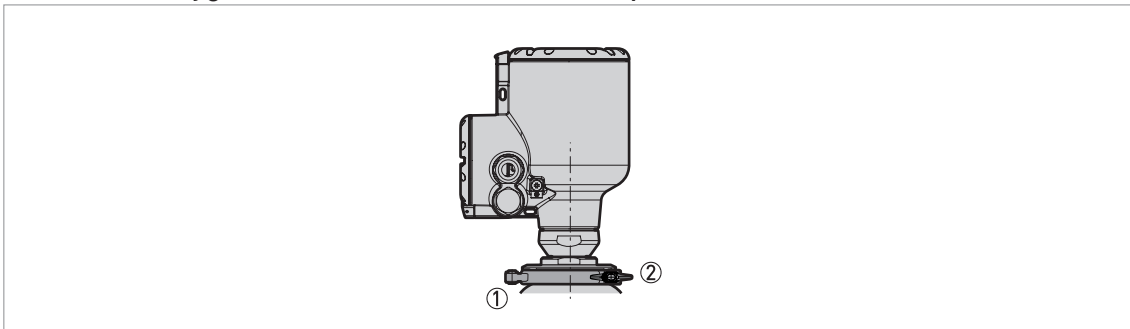

Figure 3-11: VARIVENT® connection: installation procedure

- ① Tank socket (VARIVENT® Access Unit – not supplied)
- ② Clamp

*You can only use EHEDG-approved devices that have a VARIVENT® connection with an EPDM O-ring.*



### 4.1 Electrical installation: output options with cable gland

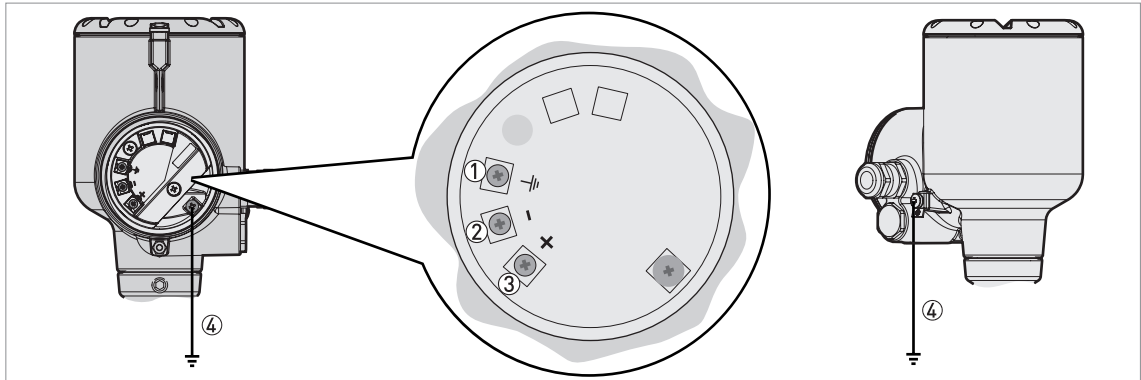

Figure 4-1: Terminals for electrical installation: standard cable gland

- ① Grounding terminal in the housing (if the electrical cable is shielded)
- ② Current output -
- ③ Current output +
- ④ Location of the external grounding terminal (at the bottom of the converter)

*Electrical power to the output terminal energizes the device. The output terminal is also used for HART® communication.*

### 4.2 Electrical installation: output options with an M12 male connector

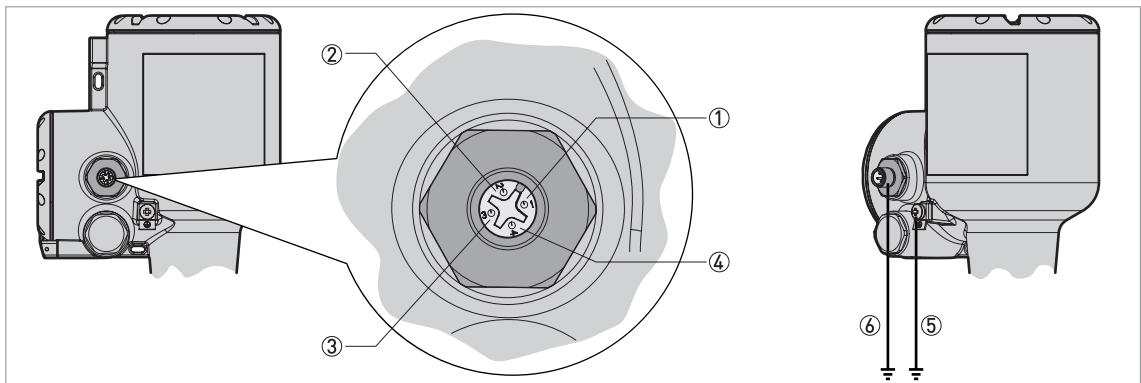

Figure 4-2: Terminals for electrical installation: 4-pin male M12 connector

- ① Pin 1: current output +
- ② Pin 2: not connected
- ③ Pin 3: current output -
- ④ Pin 4: not connected
- ⑤ Grounding terminal (external thread of the connector)
- ⑥ Location of the external grounding terminal (at the bottom of the converter)

*Electrical power to the output terminal energizes the device. The output terminal is also used for HART® communication.*

### 4.3 Non-Ex devices

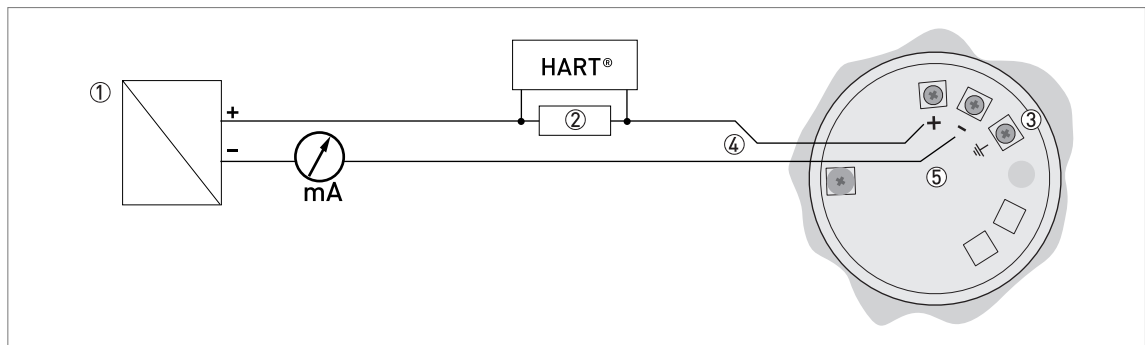

Figure 4-3: Electrical connections for non-Ex devices

- ① Power supply
- ② Resistor for HART® communication (typically 250 ohms)
- ③ Optional connection to the grounding terminal
- ④ Output: 12...30 VDC for an output of 21.5 mA at the terminal
- ⑤ Device

### 4.4 Devices for hazardous locations

*For electrical data for device operation in hazardous locations, refer to the related certificates of compliance and supplementary instructions (ATEX etc.). This documentation can be downloaded from the website.*

## 4.5 Networks

### 4.5.1 General information

The device uses the HART® communication protocol. This protocol agrees with the HART® Communication Foundation standard. The device can be connected point-to-point. It can also have a polling address of 1 to 63 in a multi-drop network.

The device output is factory-set to communicate point-to-point. To change the communication mode from **point-to-point** to **multi-drop**, refer to "Network configuration" in the handbook.

### 4.5.2 Point-to-point connection

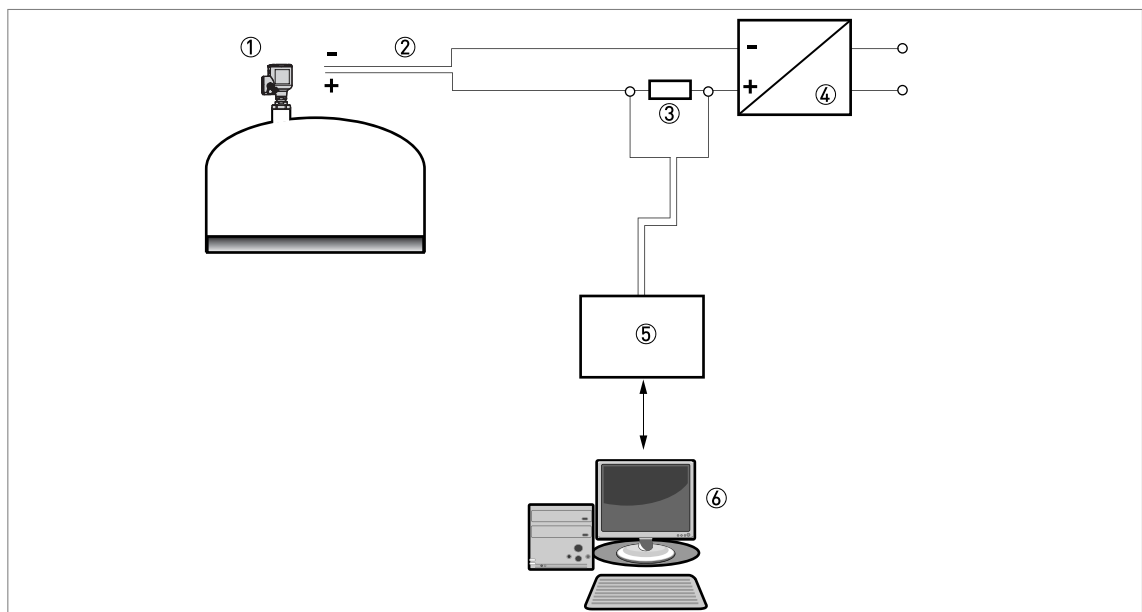

Figure 4-4: Point-to-point connection (non-Ex)

- ① Address of the device (0 for point-to-point connection)
- ② 4...20 mA + HART®
- ③ Resistor for HART® communication (typically 250 ohms)
- ④ Power supply
- ⑤ HART® converter
- ⑥ HART® communication software

## 4.5.3 Multi-drop networks

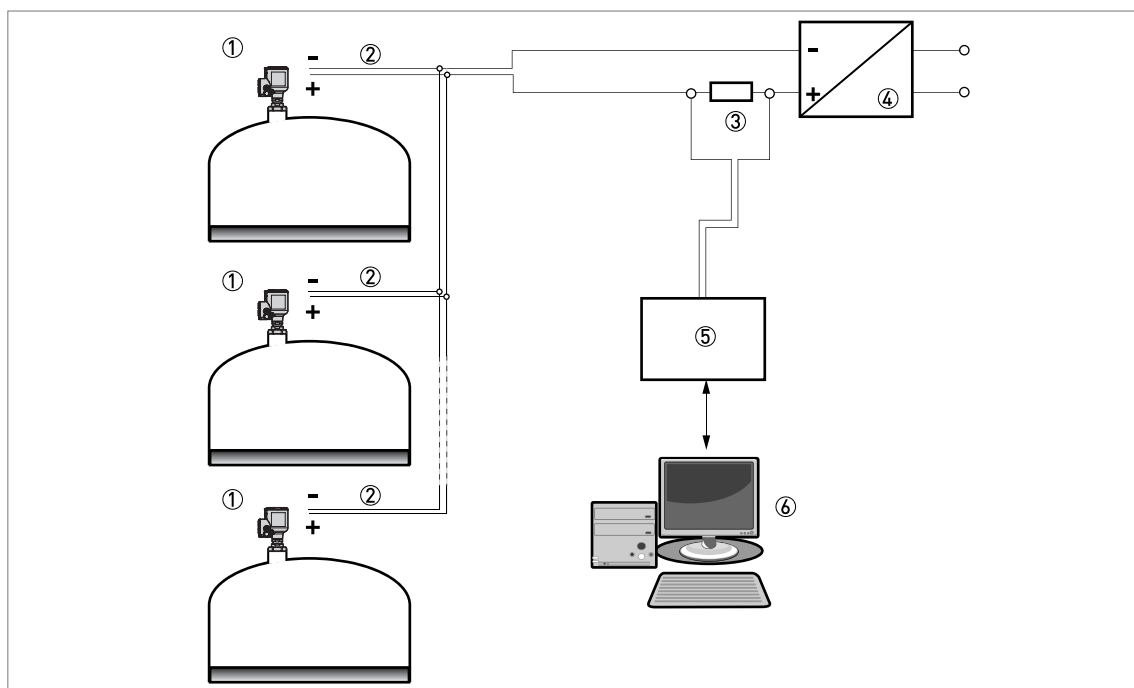

Figure 4-5: Multi-drop network (non-Ex)

- ① Address of the device (each device must have a different address in multidrop networks)
- ② 4 mA + HART®
- ③ Resistor for HART® communication (typically 250 ohms)
- ④ Power supply
- ⑤ HART® converter
- ⑥ HART® communication software

### 5.1 Order code

Make a selection from each column to get the full order code.

S80H	4	D	<b>Senator S80H Radar - 80 GHz radar (FMCW) level transmitter for liquids with hygienic requirements (up to 40 barg (580 psig) and 150°C (302°F))</b>
			<b>Regional directives</b>
			1 Europe
			2 China
			3 USA
			4 Canada
			5 Brazil
			6 Australia
			A Russia
			B Kazakhstan
			C Belarus
			W Worldwide
			<b>Ex approvals</b>
			0 Without
			1 ATEX II 1/2 G Ex ia IIC T6...T3 Ga/Gb + II 1/2 D Ex ia IIIC T85°C...T150°C Da/Db ①
			2 ATEX II 1/2 GD Ex db ia IIC T6...T3 Ga/Gb + II 1/2 D Ex ia tb IIIC T85°C...T150°C Da/Db ①
			3 ATEX II 3 G Ex ic IIC T6...T3 Gc + II 3 D Ex ic IIIC T85°C...T150°C Dc ①
			4 ATEX II 3 G Ex nA T6...T4 Gc ①
			5 NEPSI Ex ia IIC T6...T3 Ga/Gb + Ex iaD 20/21 T85°C...T150°C IP6X ①
			6 NEPSI Ex d ia IIC T6...T3 Ga/Gb + Ex iaD tD A20/A21 T85°C...T150°C IP6X ①
			A cQPSus IS CL I/II/III DIV 1 GP A-G + CL I Z0 AEx ia/Ex ia IIC T6...T3 Ga + Z20 AEx ia/Ex ia IIIC T85°C...T150°C Da ①
			B cQPSus XP-IS/DIP CL I DIV 1 GP A-G + CL I Z1 AEx db ia/Ex db ia IIC T6...T3 Gb + Z21 AEx ia tb/Ex ia tb IIIC T85°C...T150°C Db ②
			C cQPSus NI CL I/II/III DIV 2 GP A-G + CL I Z2 AEx nA/Ex nA IIC T6...T3 Gc ①
			K IECEX Ex ia IIC T6 Ga/Gb + Ex ia IIIC Da/Db ①
			L IECEX Ex d ia IIC T6...T3 Ga/Gb + Ex ia tb IIIC T85°C...T150°C Da/Db ①
			M IECEX Ex ic IIC T6...T3 Gc + Ex ic IIIC T85°C...T150°C Dc ①
			<b>Industry / Safety</b>
			A Food contact (FDA / EC 1935/2004 + EC 2023/2006 and EU 10/2011)
			B Food contact (FDA / EC 1935/2004 + EC 2023/2006 and EU 10/2011) + 3-A® ①
			C Food contact (FDA / EC 1935/2004 + EC 2023/2006 and EU 10/2011) + EHEDG ③
<b>S80H</b>	<b>4</b>	<b>D</b>	<b>0 Order code (complete this code on the pages that follow)</b>



															<b>Antennas (antenna type, material, radio approval)</b>															
															2	Lens, DN25 (1") / PEEK / TLPR ⑦														
															3	Lens, DN40 (1½") / PEEK / LPR ⑧														
															0	<b>Process connection: Size / Pressure class / Type</b>														
															Hygienic (surface roughness, Ra <0.8 µm / 32 µin – AARH)															
															G	F	S	1½" Tri-Clamp® ISO 2852 / 3-A®												
															H	F	S	2" Tri-Clamp® ISO 2852 / 3-A®												
															G	F	T	DN40 DIN 11851												
															H	F	T	DN50 DIN 11851												
															H	F	U	DN51 SMS 1145 ⑨												
															H	D	V	DN50 VARIVENT® Type N / EHEDG												
															H	F	W	DN50 NEUMO BioControl® with EPDM gasket												
															G	F	X	DN40 DIN 11864-1 Form A ⑨												
															H	F	X	DN50 DIN 11864-1 Form A ⑨												
															<b>Calibration certificate</b>															
															0	Without: Accuracy ±2 mm (±0.08")														
															1	Calibration certificate ±2 mm (±0.08") up to 10 m (32.81 ft), 2 points														
															2	Calibration certificate ±2 mm (±0.08") up to 10 m (32.81 ft), 5 points														
															3	Calibration certificate ±2 mm (±0.08") up to 10 m (32.81 ft), 5 points specified by the customer min. ≥ 400 mm (16")														
															<b>Options</b>															
															0	Without														
															5	Electropolished wetted parts														
															<b>Accessories / Tag plate</b>															
															0	Without														
															1	Weather protection														
															3	Stainless steel Tag plate (18 characters max.)														
															6	Weather protection + Stainless steel Tag plate (18 characters max.)														
<b>S80H</b>															4	D			0				0							<b>Order code</b>

- ① Pending
- ② Pending. DIP = Dust Ignition Proof.
- ③ For Tri-Clamp®, DIN 11851, VARIVENT® and DIN 11864-1 Form A connections
- ④ This housing option has Ex ia and Ex ic approvals. The Ex d approval for this option is pending.
- ⑤ For DN25 (1") Lens antenna with the adaptor for DN50 VARIVENT® Type N
- ⑥ For all Lens antennas and process connections, but do not use with the adaptor for DN50 VARIVENT® Type N
- ⑦ Not available with the DN50 NEUMO BioControl® process connection. LPR = You can install the antenna in a closed tank or outdoors, but the antenna must point down. Do install LPR devices near sensitive installations (e.g. a radio astronomy station). TLPR = You must install the antenna in a closed tank.
- ⑧ Only available with the 2" Tri-Clamp® and DN50 NEUMO BioControl® process connections. LPR = You can install the antenna in a closed tank or outdoors, but the antenna must point down. Do install LPR devices near sensitive installations (e.g. a radio astronomy station). TLPR = You must install the antenna in a closed tank.
- ⑨ The process connection includes the ring nut

**Hawk Measurement Systems (Head Office)**

15 - 17 Maurice Court Nunawading VIC 3131, AUSTRALIA

Phone: +61 3 9873 4750

Fax: +61 3 9873 4538

info@hawk.com.au

**Hawk Measurement**

90 Glenn Street, Suite 100B, Lawrence, MA 01843, USA

Phone: +1 888 HAWKLEVEL (1-888-429-5538)

Phone: +1 978 304 3000

Fax: +1 978 304 1462

info@hawkmeasure.com

For more information and global representatives: [www.hawkmeasure.com](http://www.hawkmeasure.com)

